

**WASHINGTON COUNTY
RURAL WATER DISTRICT NO. 3**

**STANDARD SPECIFICATIONS DOCUMENT
FOR
WATER LINE
MATERIALS AND CONSTRUCTION**

REVISION DATE

May 2025

STANDARD SPECIFICATIONS FOR WATER LINE MATERIALS AND CONSTRUCTION

The specifications contained herein represent the minimum requirements for all Engineers, Contractors and Developers performing work in the Washington County Rural Water District No. 3 (hereinafter referred to as the "District") service boundary. The District reserves the right to change these specifications at any time.

No exceptions to the stated requirements of these specifications will be allowed unless otherwise accompanied by a change order or qualifying addendum that has been prepared in an approved written format properly documenting the acceptance by the District's Board and/or its authorized agents. The District's prior use of any materials not specifically covered in these specifications does not warrant future acceptance of the same.

The materials shown and/or described in the Standard Details included at the end of this document are required regardless of any further specification description made herein. In the event of a discrepancy between the drawings and the Standard Details shown in this document, the Standard Details included in this document will supersede those shown on the drawings.

All materials used on District projects shall be approved before being used. Material submittal data (e.g., vendor specification sheets) shall be provided in hard and/or soft copy format for District review, comment, and approval. All materials must be approved before the District will schedule a pre-construction conference.

100 GENERAL REQUIREMENTS

101 SCOPE

This specification is to govern the furnishing of all materials, labor, equipment, tools, superintendence, and other services necessary to engineer and construct water mains within the District's service boundary, complete with appurtenances including extensions and relocations at the locations shown on the plans or as specified. This specification covers materials for water lines having a diameter of two (2) through 12 inches.

102 CODES, SPECIFICATIONS AND STANDARDS

Codes, specifications and standards referred to by title or number shall form a part of this specification to the extent required by the references thereto. Latest revisions shall apply in all cases. Specific reference standards include:

Title 252, Oklahoma Administrative Code, Chapter 626, Public Supply Construction Standards, Oklahoma Department of Environmental Quality (ODEQ)

Water Supply Operations, Volume 3, AWWA

Backflow and Cross-Connection Manual, AWWA

103 SUBMITTALS

Developers and/or contractors shall submit a minimum of three (3) copies of all required submittals for review, comment and approval by the District. One (1) copy of the submittal will be returned to the developer/contractor with comments and/or approval. The following shall be submitted for each project:

Product brochures showing performance data, physical characteristics and dimensional layouts for piping, fittings, valves, hydrants, pumps and other components of the proposed water line system(s) and related components.

Manufacturer's Certificate of Compliance certifying compliance with the applicable specifications and standards.

Certified copies of test reports of factory tests required by applicable standards.

200 MATERIALS

201 PIPE

Unless otherwise specified or shown on the plans or in the details, all water line shall be Polyvinyl Chloride (PVC) in accordance with the specifications included herein.

A. Polyvinyl Chloride (PVC) Pipe

1. Polyvinyl chloride pipe (PVC pipe) shall meet the requirements of ASTM D2241. PVC pipe shall be manufactured from PVC 1120 material and shall have an SDR 21 pressure rating (200 psi) for all diameter pipes, unless otherwise stated on the drawings.
2. PVC pipe shall have an outside diameter based on the IPS system.
3. Joints between pipe sections and between pipe and fittings shall be the bell-and-spigot type with flexible elastomeric gaskets conforming to ASTM D 3139. Elastomeric gaskets incorporated in the bell end shall conform to ASTM F 477.
4. Pipe installation shall be in accordance with the latest revision of AWWA M23. Installation precautions shall conform to applicable sections of ASTM D 2774.
5. PVC pipe as manufactured by Northern Pipe, Westlake Pipe and Fittings (formerly North American), Sanderson Pipe, Diamond Plastics, or Pipelife Jet Stream are considered acceptable. All other manufacturers are subject to review and approval by the District.

B. Fittings

1. All fittings 2-inches and larger in diameter shall be ductile iron. Fittings shall meet the requirements of ANSI/AWWA C153/A21.53 and ANSI/AWWA C111/A21.11. Fittings that are flanged shall be C110 full body. All fittings shall be designed and manufactured for a pressure rating equal to or greater than that which is required for the pipe.
2. The fittings shall be cement-lined and seal coated in accordance with ANSI A21.4/AWWA C104.
3. Unless otherwise noted or called out on the plans all fitting joints shall be mechanical joint. Mechanical joints shall meet the requirements of ANSI A21.11/AWWA C111. All retainer glands shall be full body. Split glands will only be considered for use on connection where full body cannot be used.
4. All fittings shall be restrained mechanically with Midco Perma-Grip Restrained Joint System and with thrust blocking.

5. Only those fittings that are domestically manufactured by Tyler are considered acceptable. All other manufacturers are subject to review and approval by the District.

C. Adapters and Restrained Joints

1. Adapters from PVC water pipe to flanged joint valves or fittings shall be ductile iron. Adapters shall meet the requirements of ANSI A21.10/AWWA C110. The adapters shall be designed and manufactured for a pressure rating compatible with that of the pipe.
2. The adapters shall be cement-lined, and seal coated in accordance with ANSI A21.4/AWWA C104.
3. Unless otherwise noted in the plans or specifications, all restrained joints shall be made up with the MIDCO Perma-Grip Restrained Joint System. No alternatives will be considered or approved.
4. Adapter ends connecting to flange joint valves or fittings shall have joints complying with the specifications for the applicable valves or fittings.
5. Pipe Bell Joint Restraints shall be domestically manufactured Ford Uni-Flange Series spacers (preference is model 1350 or 1390) or Smith-Blair Bell-Lock Model 165. All other manufacturers of similar restraints are subject to review and approval by the District.

D. Gaskets

1. Gaskets for polyvinyl chloride push-on joints shall meet the requirements of ASTM D 3139.
2. Gaskets for mechanical joints shall meet the requirements of ANSI A21.11/AWWA C111. Properly sized transition gaskets shall be used between PVC and ductile iron fittings.

E. Nuts and Bolts

1. Nuts and bolts for mechanical joints shall be high strength, heat-treated, cast iron. Nuts shall be hexagon nuts. Bolts shall be tee head bolts. Nuts and bolts shall meet the requirements of ANSI A21.11/AWWA C111.

F. Polyethylene (PE) Pipe

1. Polyethylene (PE) pipe shall be AWWA and NSF approved for potable water contact. Acceptable manufacturers of PE pipe and fitting include Performance Pipe, Rinker, Lampson, +GF+ Central and/or J.M. Poly Pipe. All other manufacturers are subject to review and approval by the District.
2. All PE pipe shall be furnished with an affidavit from the manufacturer stating that the pipe meets the requirements of these specifications.
3. Polyethylene (PE) pipe shall conform to ASTM 3350 and NSF-61 standard #14 for potable water pipe, and AWWA C-901 (latest revision). All pipe shall be PE4710 with a minimum of DR 11 (200 psi). The pipe size shall be as shown on the plans. The PE pipe shall be heat fusion bonded.
4. All fittings used in PE pipe installations will be ductile iron in accordance with the "Fittings" section of this specification. When PE fittings are required for PE pipe,

they shall conform to ASTM 3350 and NSF-61 Standard #14 and AWWA C-901 and AWWA C-906.

5. All transitions and/or connections from PE pipe to PVC pipe shall be through a ductile iron fitting. The PE shall connect to the MJ end of a ductile fitting via a IPS MJ Adaptor. All approved PE fittings (i.e., MJ Adapters and Wall Anchors) should be provided by the manufacturer of the PE pipe that is approved. All manufacturers are subject to review and approval by the District.
6. All transitions shall be properly restrained using either an approved PE wall anchor or PVC pipe joint restraints.
7. PE pipe for service lines shall be one (1) inch diameter SDR-9 (250 psi) CTS – O.D. controlled (ASTM D2737) with plastic inserts.
8. PE pipe for services lines shall be “EndoPure” PE-4710 SODR-9 by ENDOT Industries; or Ultra-Pure Blue 4710 CTS SDR-9 by Silver-Line Plastics. All other manufacturers are subject to review and approval by the District.

G. Ductile Iron Pipe

1. Ductile iron pipe (DIP) shall conform to, and be tested in accordance with, the current American National Standard for Ductile Iron Pipe, Centrifugally Cast in Metal Molds or Sand-Lined Molds, for Water or Other Liquids, ANSI/AWWA C151/A21.51. Ductile iron pipe will only be approved for specific applications. Where the required DIP pipe size is 12-inch or smaller, a thickness class of 51 shall be provided, unless otherwise noted in the plans.
2. DIP pipe as manufactured by US Pipe or McWane Ductile are considered acceptable. All other manufacturers are subject to review and approval by the District.

202 VALVES

- A. Gate Valves: Buried gate valves shall be iron body, non-rising stem resilient seat gate valves. Valves shall meet or exceed the minimum requirements of AWWA C509 and be certified to ANSI/NSF 61. The interior and exterior surfaces of the valve shall be fusion epoxy coated with a minimum 10 mil thickness. Unless otherwise noted on the plans or in the specifications valve opening direction shall generally be to the left. All 2” valves shall have a minimum design working pressure of 250 psi; all 4” through 12” valves shall have a minimum working pressure of 350 psi. Gate valves shall be Mueller Model A-2360 for 2”; and Model A-2361 for 4” through 12” with mechanical and/or flanged joint ends as required.
- B. Pressure-Reducing Valves: Pressure-reducing valves shall be designed to provide tight shutoff under conditions of no flow and shall not "hunt" under ordinary flow conditions. Pressure-reducing valves shall be suitable for operation under the pressure and flow conditions as shown on the plans, or as specified for each application.
- C. Air Relief Valves: Air-relief valves shall be installed at the locations indicated on the plans. Each valve assembly shall be installed complete with appropriate piping and valves as shown on the plans. All piping and isolation valves shall be brass except for the air outlet from the valve, which shall be brass or copper tubing. Unless otherwise stated on the plans, air relief valves shall be APCO Model 200A with a 1-inch inlet and 3/16-inch orifice or approved equal.

D. Tapping Valves and Sleeves: Tapping valves shall be 200 psi, iron body, resilient-seated gate valves with non-rising stems conforming with all applicable requirements of ANSI/AWWA C500 and C509, except that the outlet end shall be standard mechanical joint end conforming to ANSI A21.11/AWWA C111 and the inlet end shall have an inlet flange conforming to ANSI B16.1 for cast iron flanges, Class 125. Tapping sleeves shall be Ford style FAST.

E. Valve Appurtenances

1. Valve ends of the mechanical joint type shall conform to ANSI A21.11/AWWA C111. The end flanges of flanged valves shall conform in dimensions and drilling to ANSI B16.1 for cast-iron flanges and flanged fittings, Class 125 unless otherwise specified or shown on the drawings. The laying lengths of the flanged valves shall conform to the dimensions of ANSI B16.10.
2. Coating: All exterior surfaces of each valve shall be cleaned and painted in the shop with an epoxy coating that meets or exceeds all applicable requirements of ANSI/AWWA C550 and that is certified to ANSI/NSF 61. The interior surfaces of resilient-seated gate valves shall have a protective coating of fusion-bonded, non-toxic epoxy, which is safe for potable water.

F. Valve Operation

1. Gate valves shall be equipped with an AWWA 2-inch square wrench nut and the direction of rotation to open the valve shall be to the left (counterclockwise) unless otherwise noted.
2. Operators for non-buried service butterfly valves shall be of the enclosed gear-type furnished with a hand wheel and 2-inch square AWWA operating nut. Operators for buried service shall be equipped with mechanical stop-limiting devices to prevent over-travel of the disc in the open and closed positions.
3. Operators for buried service butterfly valves shall be of the totally enclosed, permanently lubricated, worm gear-type. The valves shall conform to AWWA C 504 and shall be equipped with a 2-inch square AWWA operating nut with a removable hand wheel complete with spinner and open-close indicator, suitable for one-man operation at 150 psi unbalanced across the valve. The valve indicator shall be hermetically sealed for installation inside a cast-iron valve box and shall show valve-disc position, direction of rotation, and number of turns from full open to full close.
4. Extension Stems: When the distance from the top of the valve cover to the valve-operating nut exceeds three (3) feet, each buried valve shall be provided with an extension stem and 2-inch operating nut.

G. Curb/Corporation Stops:

1. Buried valves smaller than 2-inch diameter shall be curb/corporation stops. Curb/corporation stops shall be all brass Ford Model F-1100 or Mueller H-15028 [Male Iron Pipe Thread Inlet by Pack Joint for Plastic tubing (CTS) Outlet]. Tapered threads are not allowed.

203 VALVE BOXES

A. In Paved Areas:

1. Valve boxes for butterfly valves and gate valves shall be cast iron. Valve boxes shall be East Jordan 70SVB (Product No. 33470900) with a 6-inch PVC riser. Each base and bottom section shall be the proper size for the valve served. Each valve box assembly shall be the proper length for the valve served. The minimum thickness of metal shall be 3/16-inch. Cast the word "WATER" in each valve box cover.

B. In Non-Paved Areas:

1. Valve boxes shall be PVC SDR-35 provided with a mushroom style metal cap. The box shall be extended above the adjacent grade a minimum of 12 inches.

204 FLUSHING AND FIRE HYDRANT ASSEMBLY

A. General: Flushing and fire hydrants shall be dry barrel, standard compression, two-piece standpipe, break-away design conforming to AWWA C502 and shall comply with the following specifications. All hydrant assemblies shall include an isolation gate valve with valve box and lid.

1. Hydrants shall be set plumb with hose nozzles facing as directed by owner.
2. The distance from the bottom of the hose nozzle to the finished grade shall be a minimum of 18-inches and a maximum of 30-inches.
3. Unless otherwise specified or shown the distance from the center of the hydrant to the isolation branch gate valve shall be a minimum of 30-inches.
4. Hydrant shall be blocked with a plug-type concrete bearing block (4-inch x 8-inch x 16-inch) and shall be harnessed to the 6-inch hydrant branch tee. Concrete shall be poured behind the hydrant base against a solid ditch wall. Concrete blocking shall stay 3-inches below the base flange of the hydrant so the hydrant barrel weep-holes will not be blocked.
5. A sufficient quantity of granular material shall be backfilled around the hydrant to allow free drainage of the barrel. Clean gravel approximately 1-inch in diameter shall be placed around the base flange and 12-inches above the base flange of the hydrant.
6. Hydrants shall be installed in accordance with the requirements of the applicable sections of the latest revision of AWWA C600.
7. Unless otherwise noted or approved all hydrants shall be equipped with a 6-inch mechanical joint inlet connection.
8. Operating stem and nozzle cap nuts shall be 1½-inch point to flat pentagon.
9. Hydrant nozzles shall meet NFPA standard thread requirements. All nozzle caps shall be equipped with chains attached to the hydrants and shall be furnished with long life rubber gaskets meeting rubber products in automotive application, ASTM D2000 requirements.
10. The bury depth of hydrant barrel shall be three feet (3') below finish grade to the invert of the connecting pipe. Extensions shall be used to accommodate pipe at greater depths.

11. Hydrants shall be equipped with two drain holes and provided with an automatic and positively operating non-corrodible drain or dip valve so as to drain the hydrant completely when the main valve is shut.
 12. Harnessing lugs shall be furnished with the hydrants.
 13. Hydrants shall be painted red.
- B. Fire Hydrants: Fire hydrants shall conform to the "General" section above and as follows:
1. Two 2½-inch hose nozzles and one pumper nozzle, 6-inch shoe and 4½-inch barrel, mechanical valve opening left, and a 6-inch inlet connection.
 2. Hydrant models shall be Mueller A421.
- C. Flushing Hydrants: Flushing (two-way) hydrants shall conform to the "General" section above and as follows:
1. Two 2½-inch hose nozzles spaced 180 degrees apart.
 2. Hydrant models shall be Mueller, Super Centurion 200, Model A-420.

205 BEDDING AND BACKFILL MATERIALS

- A. Pipe Embedment: Unless otherwise approved the bedding for all pipe, fittings and related appurtenances shall be sand or screenings that is graded from fine to coarse, free from objectionable material, and containing no more than 10 percent clay or loam by weight. One hundred (100) percent shall pass a three-quarter inch screen, and ninety-five percent shall pass a number four (4) screen.
- B. Select Backfill: Select backfill may be excavated materials containing no rocks or other foreign objects greater than 2- inches in diameter, subject to the approval of the Engineer.
- C. Compacted Backfill: Backfill material may be excavated material, subject to the approval of the Engineer.
- D. Flowable fill shall only be used when required by the plans or when directed by the Engineer. Flowable fill shall be sand-cement slurry consisting of 2,970 lbs of sand, 100 lbs of cement, and approximately 458 lbs of water per cubic yard. The slurry will be mixed to a pourable soupy mix in a ready-mix truck. When the flowable fill is to be a Quick-Set flowable fill, the cement shall be replaced with rapid set cement and the slurry shall have strength of 65 to 75 psi in 1 to 1.5 hours.

206 CONCRETE

- A. Cast-in-Place concrete used for thrust blocks, and encasements shall achieve a minimum compressive strength of 3,000 psi at twenty eight (28) days. Concrete for structures or other uses shall conform to additional specifications as provided by the Engineer.

207 CASING PIPE, SPACERS AND PIPE BELL JOINT RESTRAINTS

- A. Major Crossings: Unless otherwise shown on the plans steel pipe (AWWA C200) shall be used for casings at all railroad and highway crossings, section line roads and major driveways. The minimum wall thickness of the steel casing pipe shall be 0.375 inches. The inside diameter of the steel casing pipe shall provide sufficient clearance on all sides of the water conveyance line as measured at its location of largest outside diameter (e.g., O.D. of bell end) with allowance made for a five (5) percent casing pipe deflection from overburden.
- B. Minor Crossings: Unless otherwise directed or shown on the plans PVC sewer pipe (SDR 35) shall be used for all service and water line road crossings inside developments. Certain

exceptions, subject to the Districts review and approval, may require the use of steel casing pipes in high traffic areas of developments. The inside diameter of the PVC casing pipe shall provide sufficient clearance on all sides of the water conveyance line as measured at its location of largest outside diameter (e.g., O.D. of bell end) with allowance made for a seven and one-half (7.5) percent casing pipe deflection from overburden.

- C. Drainage Structure Crossings: Unless otherwise shown on the plans all drainage structure crossings shall be constructed with a continuous fused section of HDPE water line pipe through HDPE casing pipe. All casing pipe shall be DR-11 unless otherwise approved. The inside diameter of the HDPE casing must be large enough to allow for the installation casing spacers.
- D. Casing Spacers: Unless otherwise shown on the plans all water line pipes installed through casing pipe, regardless of casing material or length, shall include casing spacers. Casing spacers shall be non-metallic polyethylene materials similar to that offered by Pipeline Seal & Insulator, Inc.
- E. Casing Length and Pipe Bell Joint Restraints: Where the proposed casing length exceeds 30 feet and HDPE pipe is not installed through the casing, all water line pipe bell joints located inside the casing shall be restrained mechanically with pipe bell joint restraints.

208 LOCATOR WIRE AND DETECTABLE MARKING TAPE

- A. A Number 12 (12 AWG @ 0.0808 inches in diameter) coated solid or stranded copper conductor wire for the purpose of locating the PVC pipe shall be buried along the top of the pipe and connected at each valve box. Where tracer wires must be spliced use Pro-Trace TW connectors or other approved equal. Detectable Mylar marking tape for location of PVC water pipe shall be required. The tape shall be 2-inches in width, blue in color with lettering indicating, "Caution - Water Line Below". The tape shall be buried 12 inches below the surface.

209 PRECAST MANHOLE, RING AND LID

- A. The manhole ring and lid shall be heavy duty, solid cast lid with a pick hole. The lid shall be cast flush with the top of the manhole. The word "WATER" shall be cast into the top of the lid. Deeter Foundry Models 1155 and 1156 are approved.

300 CONSTRUCTION

301 GRADING AND EXCAVATION

- A. Scope: Excavation and trenching work shall include the necessary clearing, grubbing, and preparation of the site; removal and disposal of all debris; excavation and trenching as required; the handling, storage, transportation, and disposal of all excavated material; all necessary sheeting, shoring, and protection work; preparation of subgrades; pumping and dewatering as necessary or required; protection of adjacent property; and other appurtenant work items.

B. General:

1. Excavation and trenching work shall be performed in a safe and proper manner according to OSHA regulations and suitable precautions being taken against all hazards.
2. The Contractor shall explore and expose any and all obstructions in advance of excavation so that minor changes in grade and alignment may be made.
3. In paralleling present water and gas mains, the Contractor shall protect all service connections and shall arrange to furnish service to the consumers with minimum interruption.
4. All excavated material shall be piled in a manner that will not endanger the work and that will avoid obstructing sidewalks and driveways. Gutters shall be kept clear or other satisfactory provisions made for street drainage.

C. Classification of Excavated Material: No classification of excavated materials will be made. Excavation and trenching work shall include the removal and subsequent handling of all materials excavated or otherwise removed in performance of the contract work, regardless of the type, character, composition, or condition thereof.

D. Blasting: Blasting is not permitted.

E. Unauthorized Excavation: Any part of the trench excavated below grade shall be corrected with material accepted by the Engineer, placed and compacted by the Contractor.

F. Removal of Water:

1. The Contractor shall provide and maintain adequate dewatering equipment to remove and dispose of all surface and groundwater entering excavations, trenches, or other parts of the work. Each excavation shall be kept dry during subgrade preparation and continually thereafter until the structure to be built, or the pipe to be installed therein, is completed to the extent that no damage from hydrostatic pressure, flotation, or other cause will result.
2. All excavations for concrete structures or trenches which extend down to or below static groundwater elevations shall be dewatered by lowering and maintaining the groundwater surface beneath such excavations a distance of not less than 12-inches below the bottom of the excavation.
3. Surface water shall be diverted or otherwise prevented from entering excavated areas or trenches to the greatest extent practicable without causing damage to adjacent property.
4. The Contractor is responsible for the condition of any pipe or conduit which he may use for drainage purposes, and all such pipes or conduits shall be left clean and free of sediment.
5. All dewatering shall be incidental to other items of work and shall be provided at no cost to the owner.

G. Sheeting and Shoring: Except where banks are cut back on a stable slope, excavation for structures and trenches shall be properly and substantially sheeted, braced, or shored per OSHA requirements as necessary to prevent caving or sliding, to provide protection for workmen and the work, and to provide protection for existing structures and facilities. Sheeting, bracing, and shoring shall be designed and built to withstand all loads that might

be caused by earth movement or pressure and shall be rigid, maintaining shape and position under all circumstances.

- H. Stabilization: Trench bottoms shall be firm, dense, and thoroughly compacted and consolidated; shall be free from mud and muck; and shall be sufficiently stable to remain firm and intact under the feet of the workmen. Trench bottoms which are otherwise solid, but which become mucky on top due to construction operations shall be reinforced with one or more layers of crushed stone or gravel. Not more than ½" depth of mud or muck shall be allowed to remain on stabilized trench bottoms when the pipe bedding material is placed thereon.
- I. Trench Excavation:
 - 1. The Contractor shall not open more trench in advance of pipe laying than is necessary to expedite the work. One block, or 91 m (300'), whichever is shorter, shall be the maximum length of open trench ahead of pipe laying unless by written permission of the Engineer.
 - 2. Except where tunneling or boring and jacking is specified and shown on the plans by the Engineer, all trench excavations shall be open cut.
 - 3. Stones found in the trench shall be removed for a depth of a least 6-inches below the bottom of the pipe.
- J. Alignment and Grade: The alignment and grade or elevation of the pipeline shall be as shown on the plans. The Contractor must maintain a constant check on the pipe alignment and trench depth and will be held responsible for any deviations there from.
- K. Minimum Cover:
 - 1. Except where otherwise shown, trenches shall be excavated to a depth sufficient to provide a minimum depth of backfill cover of 30 inches over the top of the pipe. Greater pipe cover depths may be necessary on existing pipe, conduits, drains, drainage structures, or other obstructions encountered at normal pipe grades.
 - 2. Measurement of pipe cover depth shall be made vertically from the outside top of pipe to finish grade or pavement surface elevations.
- L. Standard Trench Widths and Unauthorized Trench Widths: The standard trench width shall be the pipe diameter plus two (2) feet maximum. Under no circumstances shall the width be less than one (1) foot wider than the pipe diameter. The Contractor will only be paid for the standard trench width. When, for any reason, the width of the lower portion of the trench as excavated at any point exceeds the maximum permitted, either pipe of adequate strength, special pipe embedment, or arch concrete encasement, as required by loading conditions and as determined by the Engineer, shall be furnished and installed by and at the Contractor's expense.
- M. Trench Bottom in Earth: The trench in earth shall have a flat bottom the full width of the trench and shall be excavated to the grade to which the pipe is to be laid. The surface shall be graded to provide a uniform bearing and continuous support for each pipe at every point along its entire length.
- N. Bedding: The Contractor shall uniformly spread a minimum of 4-inches of sand or screenings in the bottom of all waterline trenches before any pipe or fittings are installed. Sand shall be placed in the trench simultaneously on both sides of pipe to an elevation of 6-inches above the top of the pipe, being carefully worked and hand-tamped around the pipe

in order to consolidate the sand and assure proper bedding. Backfill material shall not be placed in the trench covering the sand cushion without prior approval of the District.

- O. Backfill: From 6-inches above the pipe to 18-inches above the pipe, the trench shall be backfilled with Select Backfill by hand or by mechanical methods approved by the Engineer. Special care shall be used in placing this portion of the backfill to avoid damaging or moving the pipe. The remainder of the trench shall be backfilled with Compacted Backfill in twelve-inch increments using mechanical methods. Backfilling operation shall be completed within 100 feet or less of the finished line at all times as directed by the District. Backfill failing to meet required densities shall be removed or scarified and re-compacted as necessary to achieve specified results.
- P. Rock Exploration:
1. Unless shown otherwise on the plans or noted in the Special Conditions, no rock exploration has been made. On those projects where rock exploration has been made, test holes have been drilled at locations and intervals as shown on the plans or subsurface information report to determine the approximate location and depth of rock. Resistance to penetration was assumed to be "solid rock."
 2. This information is furnished for general reference purposes only. The Contractor must form his own opinion as to the character of materials, which will be encountered from an inspection in the ground, from his own investigation of the test-hole information, or from such other investigations of the test-hole information, as he may desire.
- Q. Trench Bottoms in Rock: All rock excavation shall be carried to a minimum of 4-inches below the bottom of the pipe. Standard bedding material shall be used to restore the trench bottom to the desired elevation and grade and to provide a uniform bearing and continuous support for the pipe along its entire length. Care shall be exercised to prevent any portion of the pipe from coming to bear on solid rock or boulders.
- R. Mechanical Excavation:
1. The use of mechanical equipment will not be permitted in locations where its operations would cause damage to trees, buildings, culverts, or other existing property, utilities, or structures above or below ground. In all such locations, hand-excavating methods shall be used.
 2. Mechanical equipment used for trench excavation shall be of the type, design, and construction, and shall be so operated that the rough trench excavation bottom elevation can be controlled, that uniform trench widths and vertical sidewalls are obtained at least from the bottom of the trench, and that trench alignment will be centered in the trench with adequate clearance between the pipe and sidewalls of the trench. Undercutting the trench sidewall to obtain clearance will not be permitted.
 3. All mechanical trenching equipment, its operating conditions and the manner of its operations shall always be subject to the approval of the Engineer.
- S. Stream Crossings: Stream crossings shall be made in accordance with these specifications and as shown on the plans. The trench width shall be standard width as defined in Section 301-L and the trench depth shall be as required to give minimum cover shown on the plans. Pipe encasement, where required, shall be in accordance with the specifications and placed as indicated on the plans. The construction of grouted riprap for erosion prevention of ditch slopes will be required at locations shown or designated on the plans.

1. Above water crossings: The pipe shall be adequately supported and anchored, protected from damage and freezing, and accessible for repair or replacement in accordance with OAC specifications.
2. Underwater Crossings: A minimum cover of 2' shall be provided over the pipe. When crossing watercourses, which are greater than 15 feet in width, the following shall be provided:
 - a. The pipe shall be of special construction, having flexible watertight joints.
 - b. Valves shall be provided at both ends of water crossings so that the section can be isolated for testing or repair; the valves shall be easily accessible, and not subject flooding; and the valve closest to the supply source shall be a manhole.

T. Highway and Railroad Crossings:

1. The Contractor shall make highway and railroad crossing in accordance with these specifications and as shown on the plans.
2. All construction or work performed and all operations of the Contractor, his employees, or his subcontractors within the limits of highway or railroad right-of-ways shall be in conformity with all the requirements and regulations, and be under the control (through the Engineer) of the authority owning or having jurisdiction over and control of the right-of-way.

302 PIPE INSTALLATION

A. General:

1. Laying of pipe; installation of valves and hydrants; and embedment and backfill shall conform to the following specifications and the details as shown on the plans.
2. Whenever pipe laying is stopped, the open end of the line shall be sealed with a watertight plug, which will prevent trench water from entering the pipe.
3. Where the pipe is to be installed inside a conduit (casing) pipe or tunnel liner, PVC or rubber skids shall be strapped to each pipe before it is placed in the conduit (casing) pipe or tunnel liner in accordance with these specifications and as shown on the plans. The ends of each casing pipe or tunnel liner shall be closed with a concrete wall or as shown on the plans. These closures shall not be constructed until all testing of the line has been completed and accepted.

B. Ductile Iron Pipe:

1. Handling: Pipe, fittings, and accessories shall be handled in a manner that will ensure installation in a sound, undamaged condition. Equipment, tools, and methods used in unloading, reloading, hauling, and laying pipe and fittings shall be such that the pipe, pipe coatings, and fittings are not damaged. Hooks shall not be used. Under no circumstances shall pipe or accessories be dropped or dumped. The Contractor shall replace pipe and fittings on which the cement lining has been broken or loosened. Where the damaged areas are small and readily accessible, the Contractor may be permitted to repair the lining. The Contractor shall repair all pipe coating, which has been damaged, before installing the pipe.
2. Cutting Pipe: Ductile iron pipe shall be cut with either a saw or an abrasive wheel. Cutting of existing cast iron pipe shall be done with either a saw or abrasive wheel, or when there is a free end, with mechanical pipe cutters. The cutting of pipe with a

torch will not be permitted. Cutting shall be done in a neat manner without damage to the pipe, or the cement lining. Cuts shall be smooth, straight, and at right angles to the pipe axis. After cutting, the end of the pipe shall be dressed with a file to remove all roughness and sharp corners.

3. **Cleaning:** The interior of all pipe and fittings shall be thoroughly cleaned of foreign matter before being installed and shall be kept clean until the work has been accepted. Such surfaces shall be wire brushed, if necessary, wiped clean, and kept clean until jointing is completed.
4. **Inspection:** Pipe and fittings shall be carefully examined for cracks and other defects immediately before installation. Spigot ends shall be examined with particular care since they are vulnerable to damage from handling. All defective, damaged, or unsound pipe and fittings shall be rejected and marked as such and removed from the site of the work.
5. **Alignment of Bell-and-Spigot Pipe:** Pipelines or runs intended to be straight shall be laid straight. Deflections from a straight line or grade shall not exceed the quantities stipulated in Tables 4 and 5 of ANSI/AWWA C600.
6. **Laying Pipe:** Pipe shall be protected from lateral displacement by pipe embedment material installed as specified. Under no circumstances shall the pipe be laid in water, and no pipe shall be laid under unsuitable trench conditions. Pipe shall be joined in the ditch.

C. Polyvinyl Chloride (PVC) Pipe:

1. **Handling:** Pipe, fittings, and other accessories shall always be handled with care to avoid damage. Under no circumstances shall they be dropped. Pipe fittings shall be handled as specified for ductile-iron pipe. Any damaged pipe shall be rejected. Cover PVC pipe with an opaque protective covering if it will be exposed to sunlight for more than three (3) weeks. The pipe shall be left stacked and no more pipe than can be installed in one (1) day shall be strung along the jobsite.
2. **Cutting Pipe:** All pipe shall be cut with a saw or special cutting tool. Cutting shall be done in a neat manner without damage to the pipe. Cuts shall be smooth, straight and at right angles to the pipe axis. After cutting, the end of the pipe shall be dressed and beveled to factory specifications. Beveling shall be done with a specifically designed beveling tool. Hand beveling will not be allowed. When cutting pipe with couplings, mark the field cut pipe end with stop marks the same distance from the end as the original factory stop mark.
3. **Cleaning:** The interior of all pipe and fittings shall be thoroughly cleaned of foreign matter before being installed and shall be kept clean until the work has been accepted. The Bell End and Plain End of all pipes shall be thoroughly cleaned before connecting pipes.
4. **Pipe Laying:** PVC pipe shall be installed in strict accordance with the requirements and instructions of the pipe manufacturer. It shall be protected from lateral displacement and deflection by pipe embedment material installed as specified for pipe embedment. No pipe shall be laid under unsuitable trench conditions. Pipe shall be joined in the ditch. Whenever pipe laying is stopped, the open end of the line shall be sealed with a watertight plug, which will prevent trench water from entering the pipe.

5. Tracer Wire: Install tracer wire and Detectable Mylar marking tape on PVC pipe in accordance with these specifications.
 - a) Tracer wire shall be extended along the top of the pipe and taped in place at 10-foot intervals.
 - b) A twisted pair of tracer wire shall be extended up the outside of every valve box to a point above the lid where it shall be doubled over and hooked to the inside of the valve box. The tracer wire shall be taped to the outside of the valve box.
 - c) Detector tape shall be installed approximately 12-inches above the water line and 18-inches below grade. Where water lines are deeper than 30-inches the Contractor shall maintain the tape depth at 18-inches below the final grade.

303 JOINTING

A. Push-on Joints:

1. The gasket seat in the bell shall be wiped clean after which the gasket shall be placed. A thick film of lubricant shall be applied to the entire inner surface of the gasket and on the spigot end of the pipe. The bell end shall not be lubricated. The lubricant and the gaskets shall be as recommended and supplied by the manufacturer of the pipe being used. The lubricant shall be odorless, tasteless, nontoxic, and suitable for use in potable water.
2. Field-cut pipe shall be bevel filed to remove any sharp or rough edges, which might otherwise damage the gasket.

B. Mechanical Joints: The mechanical joint shall be used only when shown on the plans.

C. Flanged Joints: When bolting flanged joints, care shall be taken to ensure that there is no restraint on the opposite end of the pipe or fitting which would prevent uniform gasket compression, or which would cause unnecessary stress in the flanges. Gaskets shall be red styrene butadiene rubber (SBR) meeting the requirements of ASTM D 1330 Class II and ASTM D 2000 Type AA specifications. The minimum thickness shall be 1/8-inch. One flange shall be free to move in any direction while the flange bolts are being tightened. Bell-and-spigot joints shall not be packed or assembled until all flanged joints affected thereby have been tightened. Bolts shall be tightened gradually and at a uniform rate so that gasket compression is uniform.

D. Restrained Joints: Restrained joints and anchoring joints shall be installed in strict accordance with the pipe manufacturer's recommendations.

304 CONNECTION TO EXISTING MAINS

- A. No water line tie-ins will be allowed on Mondays or Fridays.
- B. The Contractor shall furnish and install all fittings necessary to join the existing and new water mains as shown on the plans.
- C. The District shall be given at least 48 hours notice prior to turning off any water supply mains. The Contractor shall coordinate tie-ins with the District to minimize down time. The District shall be notified when any water main is closed and re-opened. In addition, the Contractor shall provide written notices in the work area to advise citizens of work to be performed.

305 POLYETHYLENE WRAPPING MATERIAL

- A. General: Polyethylene wrapping material shall be installed on ductile iron pipe and fittings.
- B. Installation: The polyethylene wrapping material shall be installed as specified in "Method A" or "Method B" below.
 - 1. Method A: Polyethylene wrap tubing shall be approximately 24 inches longer than the length of the pipe section to provide a 12-inch overlap on each adjacent pipe section. Tube ends shall be taped in place.
 - 2. Method B: Polyethylene wrap tubing shall be 12 inches shorter than the length of the pipe section with a 36-inch length of polyethylene tube centered over pipe joint and lapped over pipe section and its tubing. Tube ends shall be taped in place.
 - 3. Repairs: Any rips, punctures, or other damages to the polyethylene shall be repaired with adhesive tape or with a short length of polyethylene tube cut open, wrapped around the pipe, and secured with adhesive tape.
 - 4. Wrapping material shall be punctured at the base of fire/flushing hydrants to allow for proper hydrant weep hole function.

306 SETTING VALVES, FITTINGS, AND HYDRANTS

A. Valves and Fittings:

- 1. All valves, fittings, plugs, and caps shall be set and joined to the pipe in the manner heretofore specified for cleaning, laying, and joining pipe, except that large valves may require special support so that the pipe will not be required to support the valve weight.
- 2. Each valve shall be inspected before installation to ensure that all foreign substances have been removed from within the valve body and shall be opened and closed to see that all parts are in first-class working condition. Gate valves shall be set vertical in the horizontal pipeline. Valves and pipe shall be supported in such a manner as to prevent stress in either with no deflection in the valve/pipe joint.
- 3. Valve boxes and lids shall be installed at each valve and shall be supported and maintained centered and plumb over the operating nut of the valve. The valve box shaft shall not transmit shock or stress to the valve. Install valve box covers flush with the surface of the finished area.
- 4. All bends and tees shall be provided with thrust blocks of plain concrete, as specified. All dead ends on new mains shall be closed with plugs or caps suitably restrained to prevent blowing off under test pressure.

B. Hydrants:

- 1. All new hydrant installations shall be as shown on the plans and shall include all necessary excavation and backfill to make the installation complete.
- 2. Each hydrant shall be inspected before installation for direction of opening, nozzle size and threading, nozzle caps and chains, operating nut, and cap nut dimensions, tightness of pressure-containing bolting, cleanliness of inlet elbow and weep hole openings, and handling damage and cracks. Defective hydrants shall be corrected or replaced.

3. All hydrants shall stand plumb. The weep holes of the hydrant shall be kept clear and free to drain. The areas around each hydrant and hydrant valve shall be thoroughly compacted to prevent settlement of these areas. Weep holes shall be surrounded by 1 1/2-inch washed rock.
4. Hydrants shall be set to a grade that allows their proper operation. Traffic hydrants with breakaway joint must be set with the joint above the ground line. Hydrants behind curbs shall be placed with the hydrant centerline at least Three feet (3') from the back of curb of fire lanes and streets. Hydrants shall be rotated so as to have the pumper nozzle facing the street or rotated to face any direction as required by the Engineer.

307 THRUST RESTRAINT

- A. Hydrants: Restrained joints shall be utilized with a valve and hydrant tee. Unless otherwise noted in the plans concrete thrust blocking will also be required.
- B. Fittings: Unless otherwise specified or noted all plugs, caps, tees, bends, and other fittings, shall be provided with reaction blocking and mechanically restrained joints. Only Midco Perma-Grip Restrained Joint Systems are considered acceptable for mechanical restraints.
- C. Thrust Blocks: Vertical and horizontal reaction blocking shall be concrete as specified herein. Thrust blocks shall be installed between solid ground and the fitting. Concrete shall be located to contain the resultant thrust force and permit access to pipe and fitting joints for repairs.

308 EMBEDMENT AND BACKFILLING

- A. Pipe Embedment: Embedment for pipe shall be in accordance with these specifications and details of the laying condition as indicated on the plans.
- B. Trench Fill: Backfill for the entire length of the pipeline shall be compacted full depth of the trench above the embedment.
 1. Compacted backfill shall be finely divided job-excavated material free from debris, organic material, frozen materials, and stones larger than 6-inch in greatest dimension. Masses of moist, stiff clay shall not be used.
 2. Whenever, in the opinion of the Engineer, the material excavated from the trenches is not suitable for backfilling, or there is a deficiency of material suitable for backfilling, the Contractor shall provide suitable material. The Contractor shall remove all excess excavated materials and shall dispose of them at locations provided by the Contractor.
 3. At the option of the Contractor, compacted backfill may be either job-excavated material or standard bedding material.
 4. Backfill in streets and driveways shall be accomplished entirely with granular bedding or flowable fill as shown on the Drawings.
- C. Placement and Compaction:
 1. Job-excavated materials shall be placed in uniform layers not exceeding 12-inches in uncompacted thickness. Increased layer thickness may be permitted for non-cohesive material if the Contractor demonstrates to the satisfaction of the Engineer that the specified compacted density will be obtained. The method of compaction and the equipment used shall be appropriate for the material to be compacted and shall not transmit damaging shocks to the pipe.

2. Granular bedding used for backfilling shall be placed in uniform layers not exceeding 6-inches and compacted by slicing with a shovel or vibrating.
3. Compaction of trench backfill shall be the following percent of maximum density at optimum moisture content as determined by the Standard Proctor Test, ASTM D698:

Area	Cohesive Materials	Cohesionless Materials
Non-paved	85%	90%
Paved	Not Allowed	95%

Backfill failing to meet required densities shall be removed or scarified and re-compacted as necessary to achieve specified results.

309 DISINFECTION AND TESTING

A. Disinfection:

1. After installation, the entire main shall be flushed. The water line shall be flushed long enough to remove a minimum of 2.5 times its volume. Flushing shall be carried out until turbidity-free water is obtained from all points along the main. When flushing is complete, the Contractor shall prepare the main for disinfection.
2. The Contractor shall perform disinfection in accordance with the latest revision of all applicable AWWA standards. Disinfection of the water main shall be accomplished using a chlorine solution (chlorination). Chlorination shall conform to ODEQ and AWWA C651-05 requirements and be performed using a one percent chlorine solution prepared from granular calcium hypochlorite [0.45 kg (1 lb) of HTH per 30.3 liter (8 gallons) of water]. Water entering the new main shall receive a dose of the chlorine solution fed at a constant rate such that the concentration of free chlorine should not be less than 50 mg/l nor more than 100 mg/l.

*Approximate Quantity of Chlorine (1% Solution)
Required to Produce 50 mg/l Concentration in 100 feet of Pipe*

<i>Pipe Diameter</i>	<i>One Percent Chlorine Solution</i>
<i>in</i>	<i>Gallons</i>
4	0.35
6	0.75
8	1.27
10	1.98
12	2.79

3. The chlorinated water shall be retained in the main for at least 24 hours, during which time all valves and hydrants in the section treated shall be operated in order to disinfect the appurtenances.
4. The Owner will take water samples after the 24-hour period for two (2) consecutive days and have them tested at an ODEQ approved laboratory for bacteriological condition per the AWWA standard. The Contractor shall be responsible for providing a sample collection point that is located above grade. The collection point shall include temporary piping that terminates with a 2-inch threaded male or female connection.
5. At the end of the 24-hour periods, the treated water in all portions of the main shall have a residual of not less than 10 mg/l free chlorine.
6. Mains shall be flushed prior to placing in service. The flushing water shall be disposed of without damage to public or private property.
7. The disinfection procedure shall be repeated should the initial treatment fail to yield satisfactory results.
8. Chloramines: The same disinfection procedure described above shall be used for areas of the distribution system that utilize "chloramines" for primary disinfection.

B. Hydrostatic Testing:

1. Pressure testing can be conducted on any normal District workday. The normal workday for the District is 6:30 am to 3 pm. Testing must begin no later than 1 pm and end no later than 2 pm on the same day.
2. Preparation: The Contractor may pressure test the distribution line without the taps installed. Prior to starting the test, the District will flush the line of all dirt and air.
3. The Contractor shall perform hydrostatic pressure and leakage tests in accordance with applicable AWWA standards. Where practicable, mains shall be tested in lengths between line valves or plugs of no more than 1,500' in length.
4. Conduct test at a pressure of 150 psi measured at the highest point of the main for a duration of 30 minutes. If the line passes the test without significant pressure loss (5 psi), a leakage test shall be made at the normal operating pressure of the line (60-80 psi) for duration of two (2) hours.
5. Leakage test shall be conducted concurrently with the normal operating pressure test. Acceptable when leakage does not exceed 10 gallons per inch diameter per mile per day at 150 psi. For example, the allowable leakage on a half mile of 6-inch diameter water line is 30 gallons (i.e., 0.5 miles x 10 gallons/inch x 6-inch pipe).
6. All visible leaks at exposed joints and all leaks evident on the surface where joints are covered shall be repaired regardless of total leakage shown by the test. All pipe, fittings, valves, and other materials found to be defective under test shall be removed and replaced at the Contractor's expense.
7. Lines, which fail to meet test, shall be repaired and retested as necessary until the test requirements are met.

- C. Inspection Requirements:** The District Inspector will be on site to observe all pressure testing. The District inspector will take samples for Oklahoma Department of Environmental Quality testing. The cost of Department of Environmental Quality testing will be paid by the Contractor.

310 SURFACE RESTORATION

- A. Seeding and Sodding: All unpaved areas cut by the line of trench or excavation or damaged during the work shall be seeded or sodded when specifically indicated on the plans.
- B. Sidewalks and Driveways: The Contractor shall replace all paved sidewalk and driveway areas cut by the line of trench or excavation or damaged during the work.
- C. Streets and Curbing: All paved street, shoulder, and curbing areas cut by the line of trench or excavation or damaged during the work shall be replaced by the Contractor to conform to the lines and grades of the original pavement and shall be of equal quality, thickness, and appearance to that removed.

400 WATER MAINS NEAR OTHER UTILITIES AND STRUCTURES

401 HORIZONTAL SEPARATION

- A. Pursuant to the current Oklahoma Department of Environmental Quality (DEQ) Regulations water mains shall be located at least 10 feet horizontally from any existing or proposed sanitary sewer lines. Water mains shall be located at least five (5) feet horizontally from any existing or proposed, storm sewers, raw water lines, petroleum product lines, natural gas lines, buried electric lines, or other utilities. In cases where it is not practical to maintain proper separation, the DEQ may allow a variance on a case-by-case basis, if supported by data from the design engineer. Such deviation may allow installation of the water line closer to a sewer line, provided that the water main is in a separate trench and the sewer is constructed of water pipe and pressure tested to assure water tightness. It shall be the developer or contractor's responsibility to obtain a documented variance acceptance by the DEQ.
- B. PVC water lines shall be located at least fifty feet (50 feet) horizontally from any gasoline storage tank or line. Wherever a 50-foot separation cannot be maintained for water lines, the water line shall be cased with steel pipe of appropriate diameter and thickness. In no case shall the water line inside the required casing be closer than 10 feet to the storage tank or line(s). The distance shall be measured edge to edge.
- C. Water lines shall be located at least 15 feet from all parts of septic tanks and adsorption fields, or other sewage treatment and disposal systems. In cases where the 15-foot separation cannot be maintained, the DEQ may allow deviation on a case-by-case basis. It shall be the developer or contractor's responsibility to obtain a documented variance acceptance by the DEQ.
- D. Adequate space must be maintained for future maintenance and repair work on proposed water lines. It's for this reason that a minimum of 10 feet of horizontal separation shall be maintained between proposed water lines and new and/or existing above or below grade structures (e.g., fencing and fence post footings, sheds, entrance features, landscaping, etc.). Under no circumstance shall a proposed water line be allowed closer than 30 feet to any occupied structure (e.g., residential home or commercial office).

402 VERTICAL SEPARATION (CROSSINGS)

- A. Sewers crossing water lines shall be laid to provide a minimum vertical distance of 24 inches between the outside of the water main and the outside of the sewer. This shall be the case where the water main is either above or below the sewer. The crossing shall be

arranged so that the sewer joints will be equidistant and as far away as possible from the water main joints. Where a water main crosses under a sewer, adequate structural support shall be provided for the sewer to prevent damage to the water main.

403 SPECIAL CONDITIONS

- A. When it is impossible to obtain proper horizontal and vertical separation as stipulated above, the sewer shall be designed and constructed equal to water pipe and shall be pressure tested to assure water tightness prior to backfilling. The sewer shall be designed and constructed in accordance with ODEQ requirements.

404 SEWER MANHOLES

- A. No water line shall pass through, or come in contact with, any part of a sewer or sewer manhole.

STANDARD DETAILS

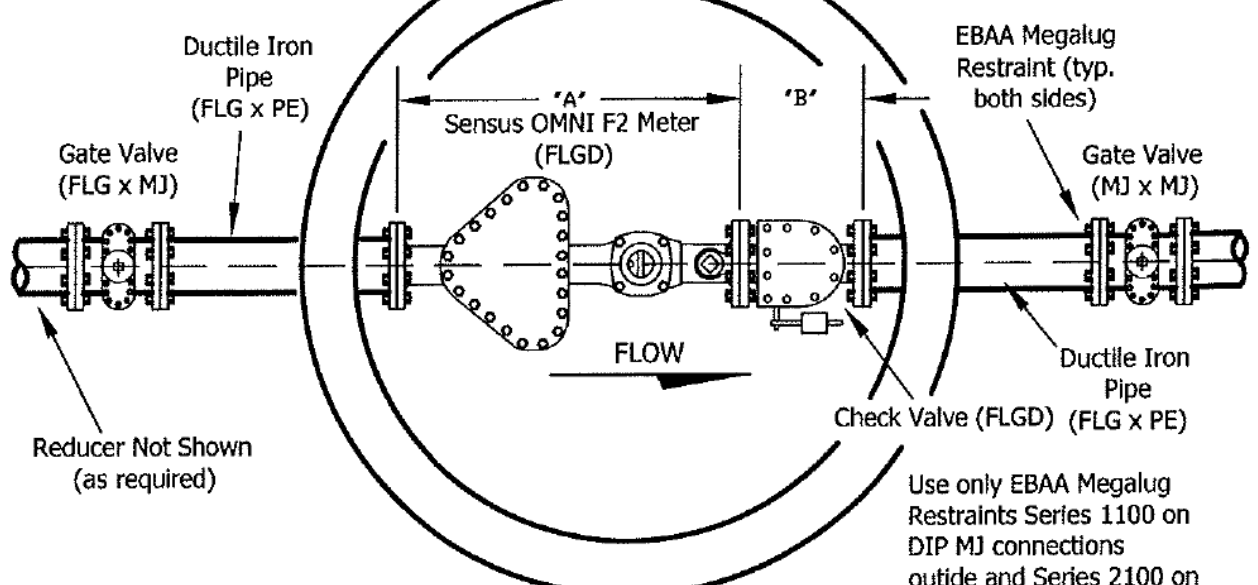
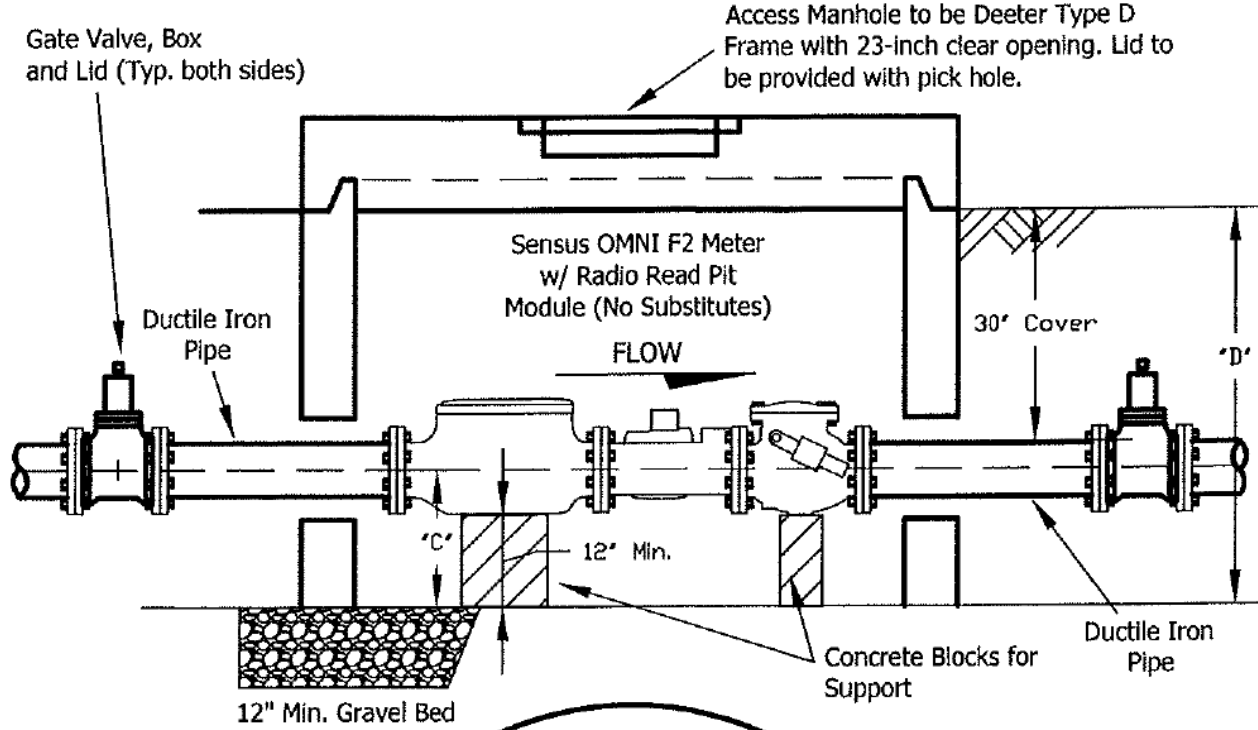

Pre-cast Manhole (MH)
 Use 8' I.D. MH For 8" Sensus OMNI F2 Meter
 Use 6' I.D. MH For 6" Sensus OMNI F2 Meter
 Use 5' I.D. MH For 4" Sensus OMNI F2 Meter

Use only EBAA Megalug Restraints Series 1100 on DIP MJ connections outside and Series 2100 on FLG connections inside (typical both sides)

FM Dia.	Max Flow (gpm)	Dimensions			
		"A"	"B"	"C"	"D"
4"	1,000	33"	12.9"	16.8"	50"
6"	2,000	45"	16"	17.8"	52"
8"	3,500	53"	19.5"	18.8"	54"

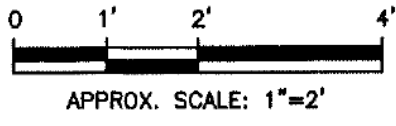

Domestic and Fire Service Meter and Vault Standard
 Washington County Rural Water District No. 3
 REV 4

REVISION DATE: JULY 16, 2021

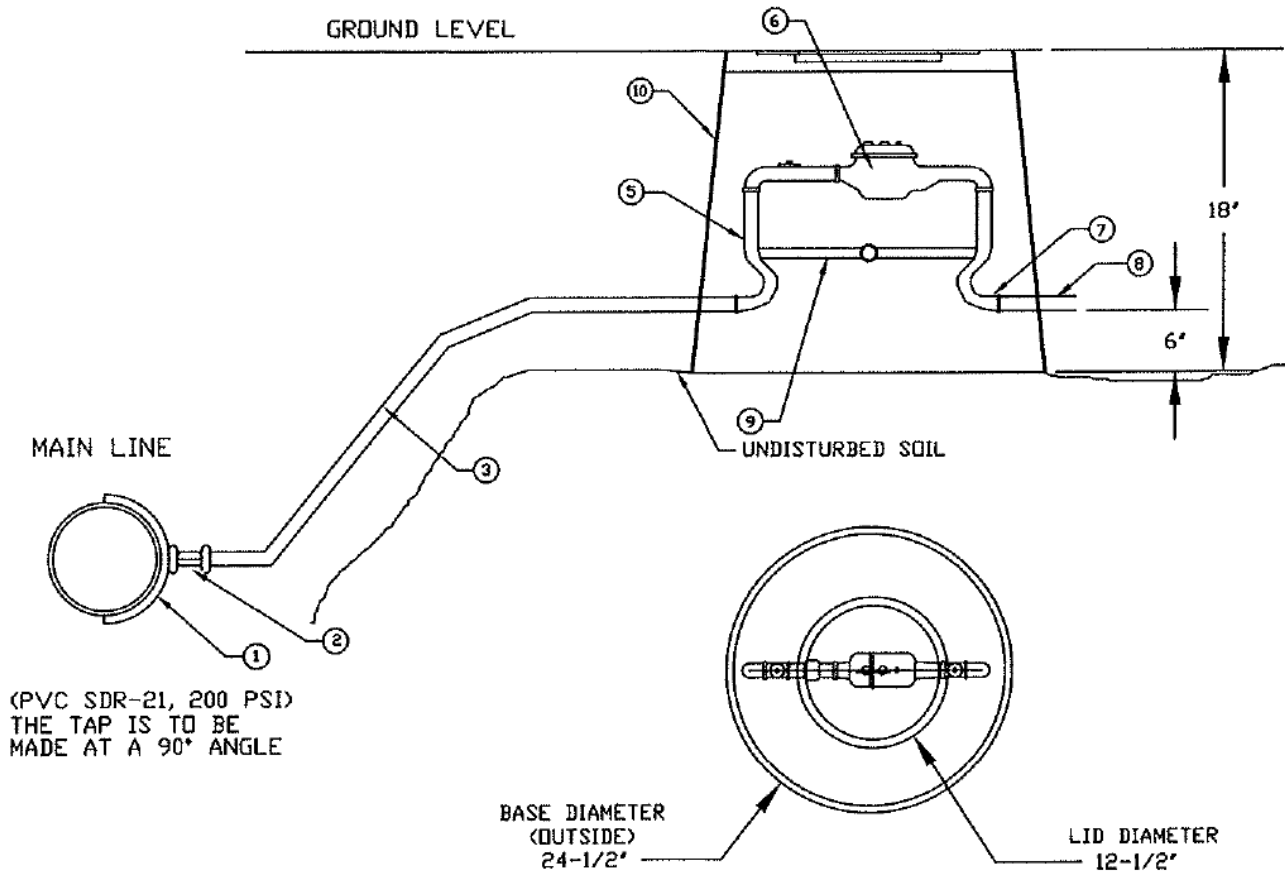

1. FORD BRASS TAPPING SADDLE (S71-XX-3 FOR 5/8" x 3/4" METER; S71-XX-4 FOR 1" METER)
2. CORPORATION STOP - FORD MODEL F-1100-X-G OR F-1100-X-IDR7; MUELLER H-15028 OR P-15028
3. POLYETHYLENE PIPE (CTS, SDR-9, CLASS 200). USE PURE-CORE BY J-M EAGLE. PLASTIC INSERT STIFFENERS REQUIRED. (3/4" DIA. FOR 5/8" x 3/4" METER) 1" DIA. FOR 1" METER)
4. NOT USED
5. CTS BY DUAL PURPOSE SETTER
 - A. 5/8" x 3/4" INSTALLATION - FORD VBH72-7W-44-33-NL, 7" RISE
 - B. 1" INSTALLATION - FORD 4-VBH74-10W-44-44-NL, 10" RISE
6. 3/4" TO 1" SENSUS METER TO BE IPERL+ (BRASS TUBE) PROVIDED WITH RADIO READ MODULE (MXU)
7. DUAL PURPOSE FITTING
8. CUSTOMER SERVICE
9. STABILIZER BAR
10. 5/8" x 3/4" INSTALLATION - USE OLDCASTLE CARSON METER CAN (NO ALTERNATES ALLOWED) MODEL 2200-18 W/ PLASTIC LID AND EXTENSIONS AS REQUIRED
1" INSTALLATION - USE OLDCASTLE CARSON JUMBO METER CAN MODEL 012-5 W/ PLASTIC LID AND EXTENSIONS AS REQUIRED

APPROX. SCALE: NONE

Water Service Meter Standard - 1" & 5/8" x 3/4"

REV
7

Washington County Rural Water District No. 3

REVISION DATE: MAY 12, 2025

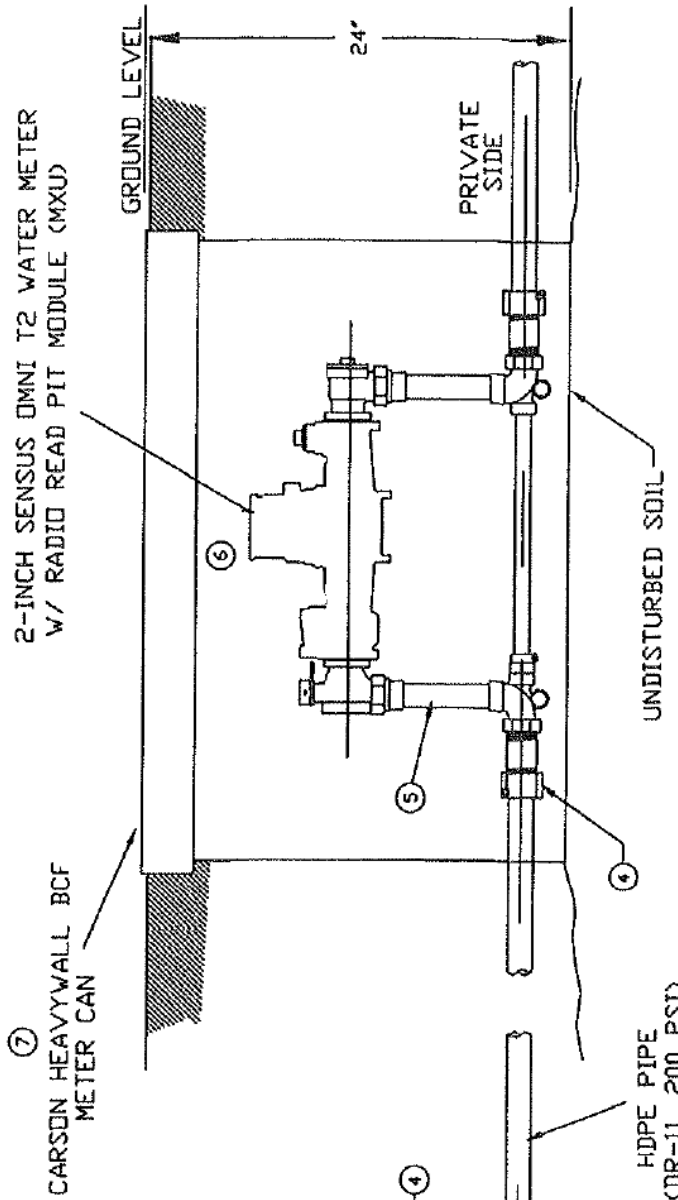

1. FORD BRASS TAPPING SADDLE (S71-XXX7)
2. 2-INCH BRASS CLOSE NIPPLE
3. 2-INCH MUELLER GATE VALVE (THREADED) - MODEL A-2360-8
4. FORD PACK JOINT COUPLING - MODEL C87-77
5. FORD METER SETTER - MODEL VBH77-12-11-77
6. SENSUS OMNI T2 METER WITH RADIO READ PIT MODULE (MXU)
7. CARSON HEAVYWALL - MODEL 1730-24 BCF (24-INCH DEPTH), PLASTIC BOLT ON COVER W/ METAL METER READ LID

NOTE:
 ALL THREADS TO BE IRON
 PIPE THREADS.

APPROX. SCALE: NONE

Water Service Meter Standard - 2"	REV 0
-----------------------------------	----------

Washington County Rural Water District No. 3

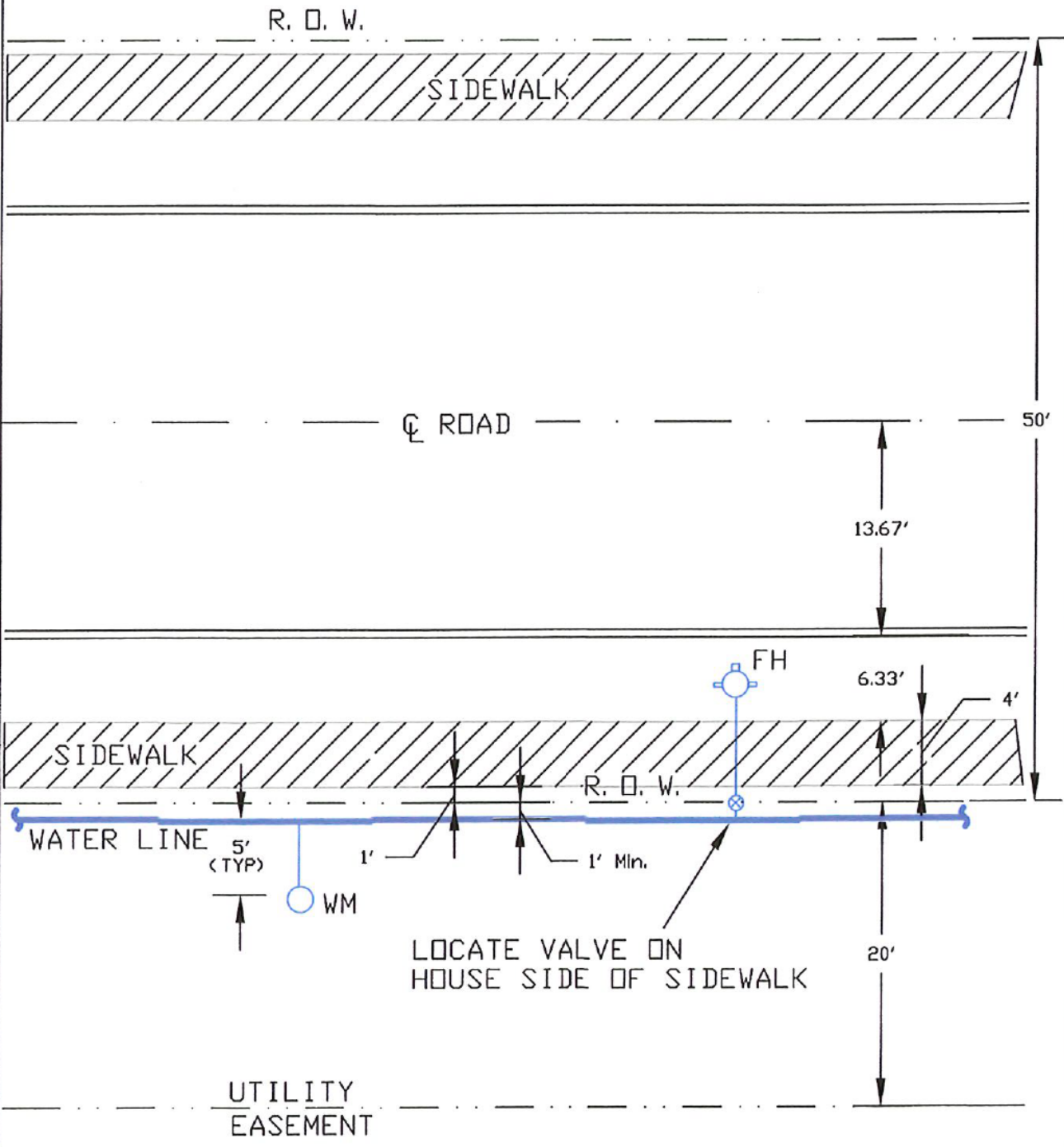

Water Lines Located in City Subdivisions	REV 0
Washington County Rural Water District No. 3	

REVISION DATE: JUNE 22, 2012

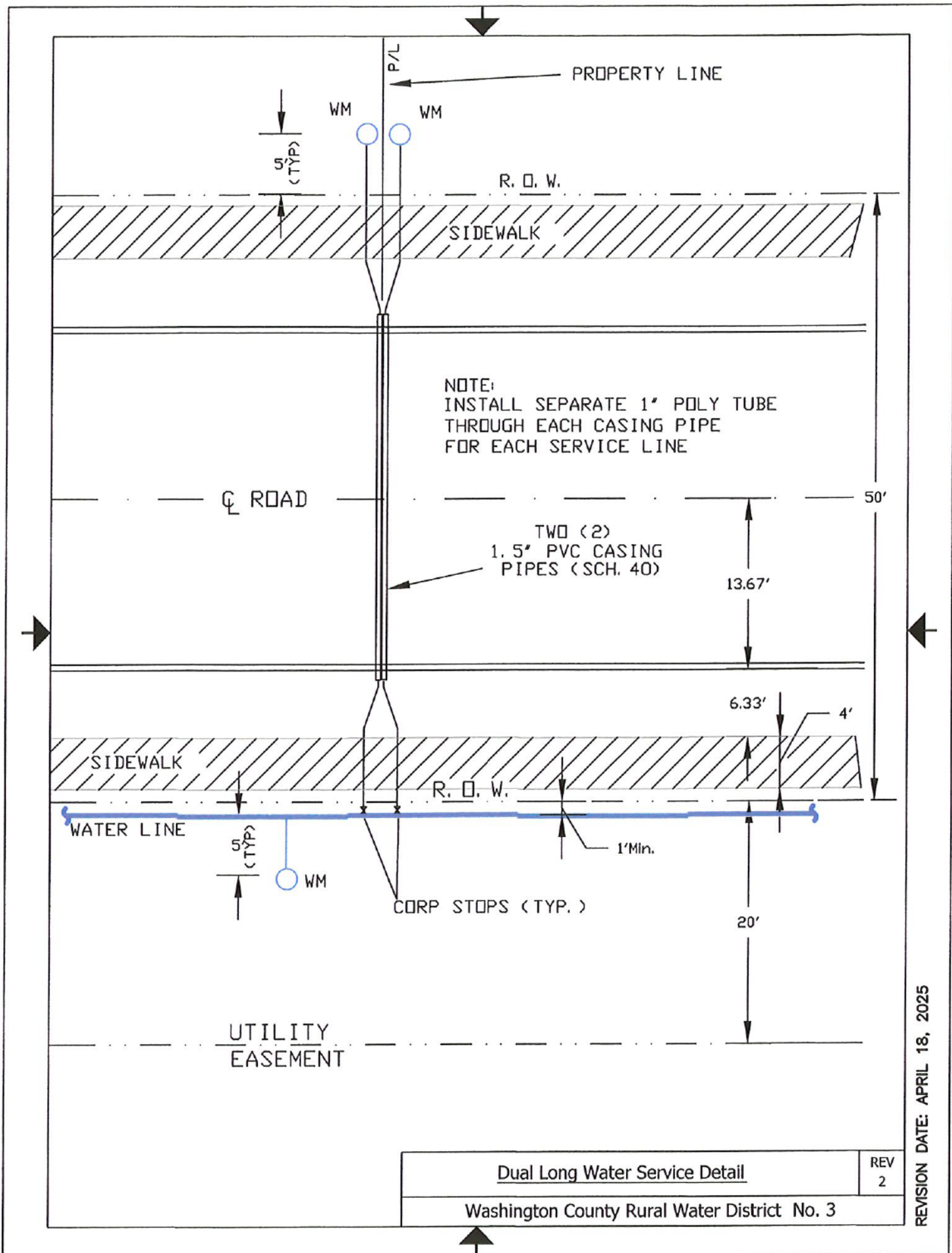

Dual Long Water Service Detail	REV 2
Washington County Rural Water District No. 3	

REVISION DATE: APRIL 18, 2025

**CASING PIPE
LONGER THAN 30 FEET**

PVC WL Dia.	Min. Casing Dia. ⁽²⁾	
	PVC ⁽¹⁾	Steel
2"	8"	8"
4"	12"	12"
6"	15"	16"
8"	18"	18"
10"	20"	20"
12"	24"	24"

(2) Pipe bell joint restraints are required.

**CASING PIPE
30 FEET OR LESS**

PVC WL Dia.	Min. Casing Dia.	
	PVC ⁽¹⁾	Steel
2"	6"	6"
4"	8"	8"
6"	10"	10"
8"	15"	14"
10"	15"	16"
12"	21"	20"

(1) PVC Casing shall be SDR 35

STEEL OR PVC (See Spec's)

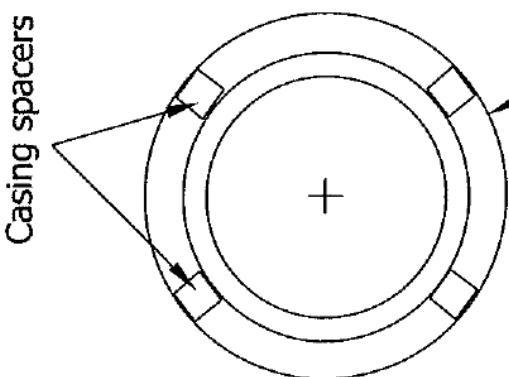

REV 0
<u>Casing Required for PVC Water Line</u>
Washington County Rural Water District No. 3

WATER LINE
HDPE DR-11 (200 psi)

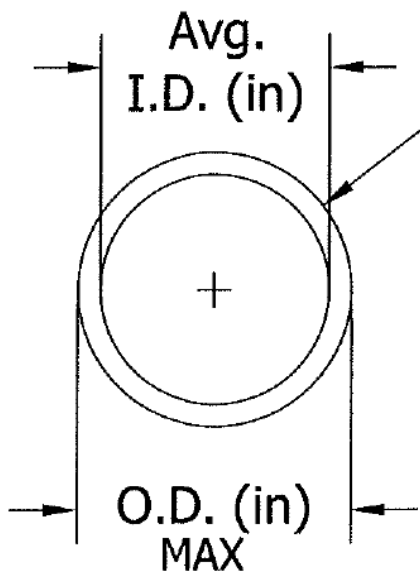

Dia.	I.D.	Max. O.D.	Max O.D. w/ Spacer
2"	1.92"	2.375"	3.7"
4"	3.63"	4.5"	5.7"
6"	5.35"	6.625"	8.7"
8"	6.96"	8.625"	11.3"
10"	8.68"	10.75"	12.7"
12"	10.29"	12.75"	14.7"

HDPE WL Dia.	Min. Casing Dia.		
	PVC ⁽¹⁾	Steel	HDPE ⁽²⁾
2"	8"	8"	8"
4"	10"	10"	10"
6"	15"	12"	14"
8"	18"	16"	18"
10"	18"	18"	20"
12"	21"	20"	24"

- (1) PVC Casing shall be SDR 35
- (2) HDPE Casing shall be minimum DR 17

Casing Required for HDPE Water Line	REV 0
Washington County Rural Water District No. 3	

REVISION DATE: SEPT. 17, 2018

NOTES:

FIRE HYDRANTS TO BE MUELLER A-421.
 FLUSHING HYDRANTS SHALL BE MUELLER SUPER
 CENTURION 200, MODEL A-420
 ALL FIRE HYDRANTS TO USE 6" MJ SHOE (MIN.)

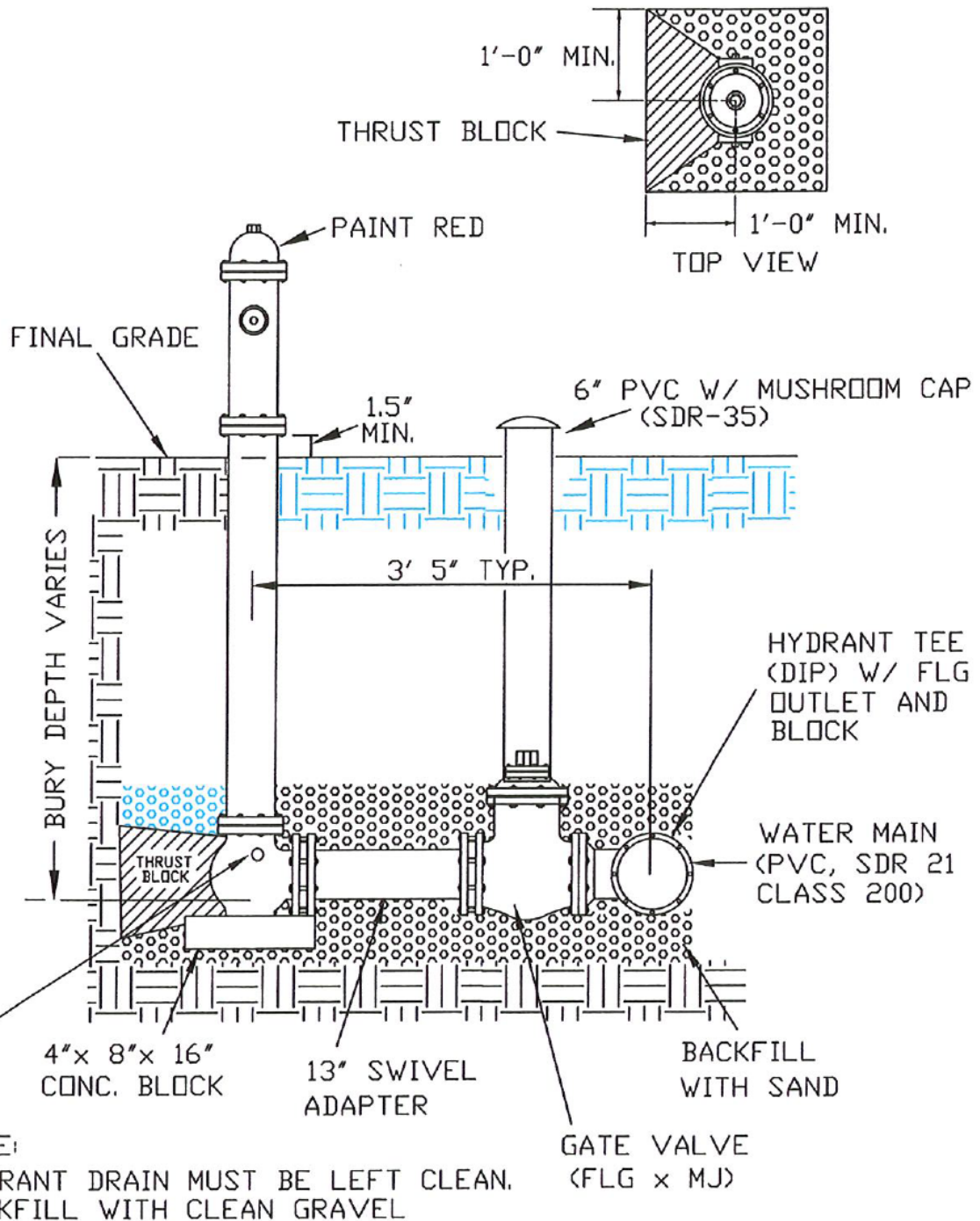

Flushing/Fire Hydrant Detail

REV
0

Washington County Rural Water District No. 3

REVISION DATE: JUNE 22, 2012

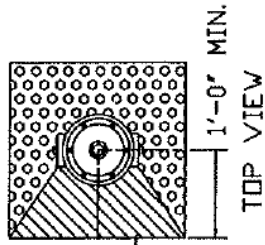

1'-0" MIN.
THRUST BLOCK

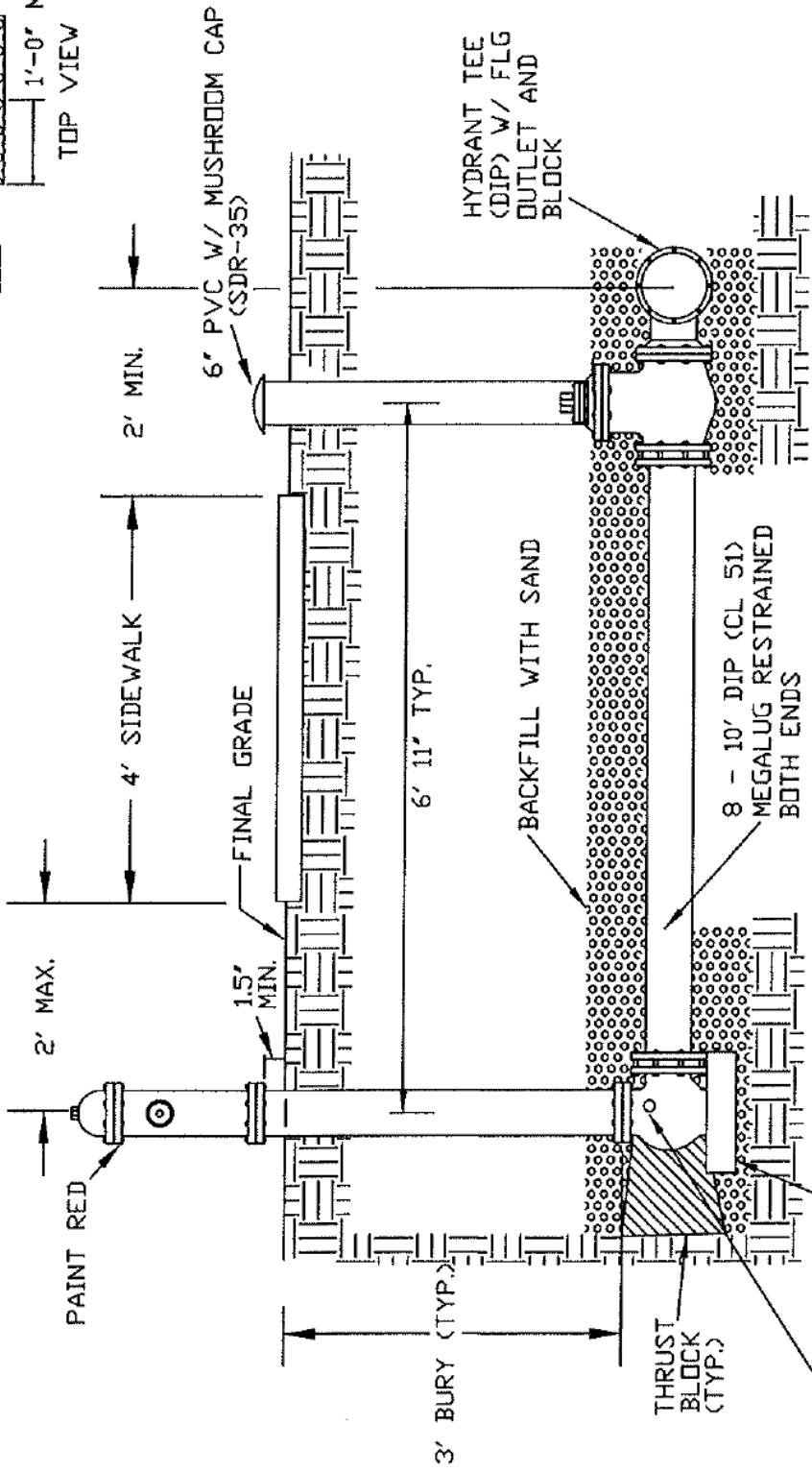

2' MAX.

2' MIN.

4' SIDEWALK

FINAL GRADE

6" PVC W/ MUSHROOM CAP (SDR-35)

HYDRANT TEE (DIP) W/ FLG OUTLET AND BLOCK

BACKFILL WITH SAND

8 - 10' DIP (CL 51) MEGALUG RESTRAINED BOTH ENDS

4' x 8' x 16" CONC. BLOCK

NOTE:

FIRE HYDRANTS TO BE MUELLER A-421.
FLUSHING HYDRANTS SHALL BE MUELLER SUPER CENTURION 200, MODEL A-420
ALL FIRE HYDRANTS TO USE 6' MJ SHOE (MIN.)

NOTE:

HYDRANT DRAIN MUST BE LEFT CLEAN.
BACKFILL WITH CLEAN GRAVEL

Flushing/Fire Hydrant with Sidewalk

REV
0

Washington County Rural Water District No. 3

REVISION DATE: JUNE 22, 2012

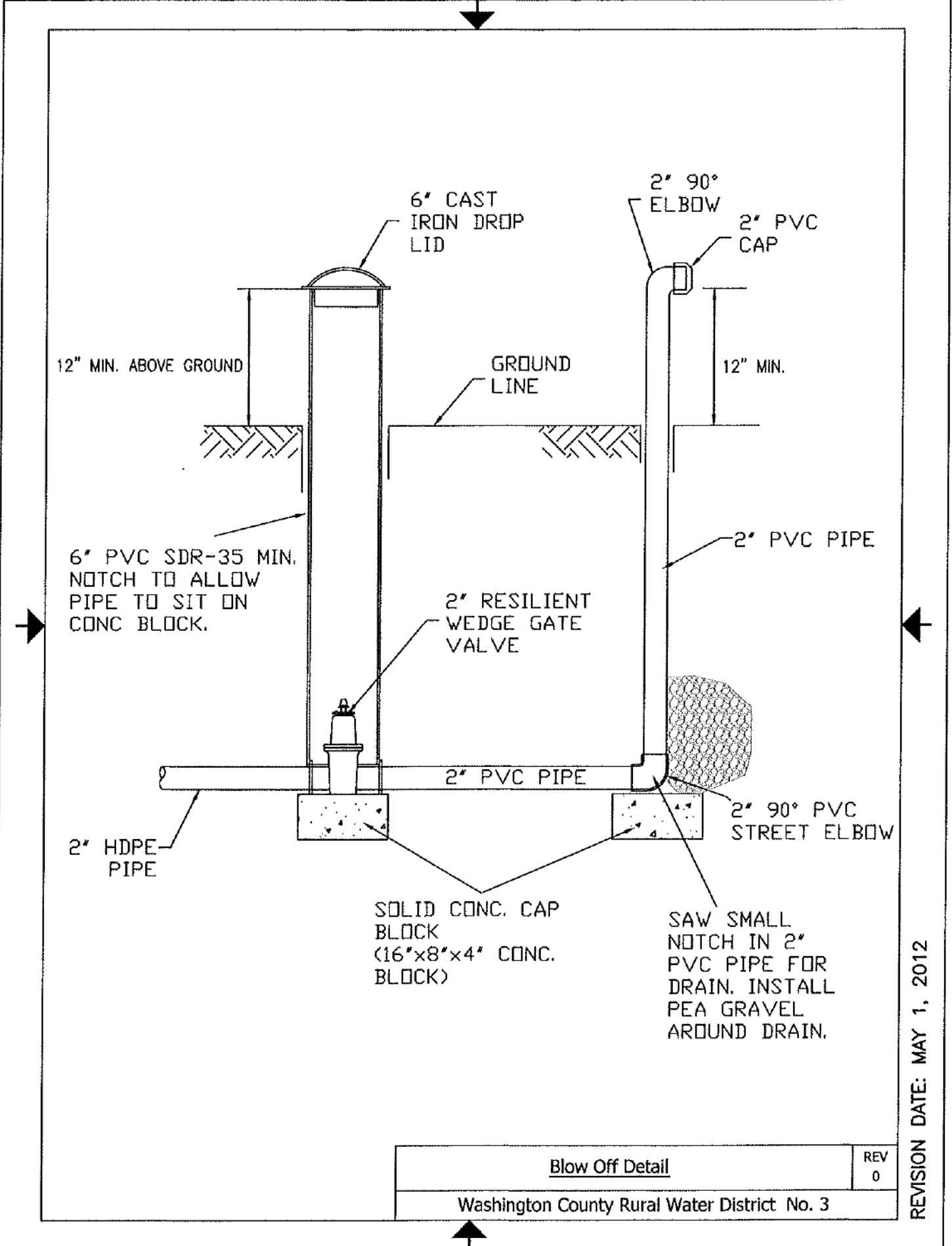

REVISION DATE: MAY 1, 2012

Blow Off Detail	REV 0
Washington County Rural Water District No. 3	

OLDCASTLE CARSON JUMBO METER CAN
MODEL 012-5 W/ PLASTIC LID AND EXTENSIONS
AS REQUIRED.

1" AIR RELIEF VALVE
DEZURIK/APCO MODEL #50
(UNLESS OTHERWISE SPECIFIED)

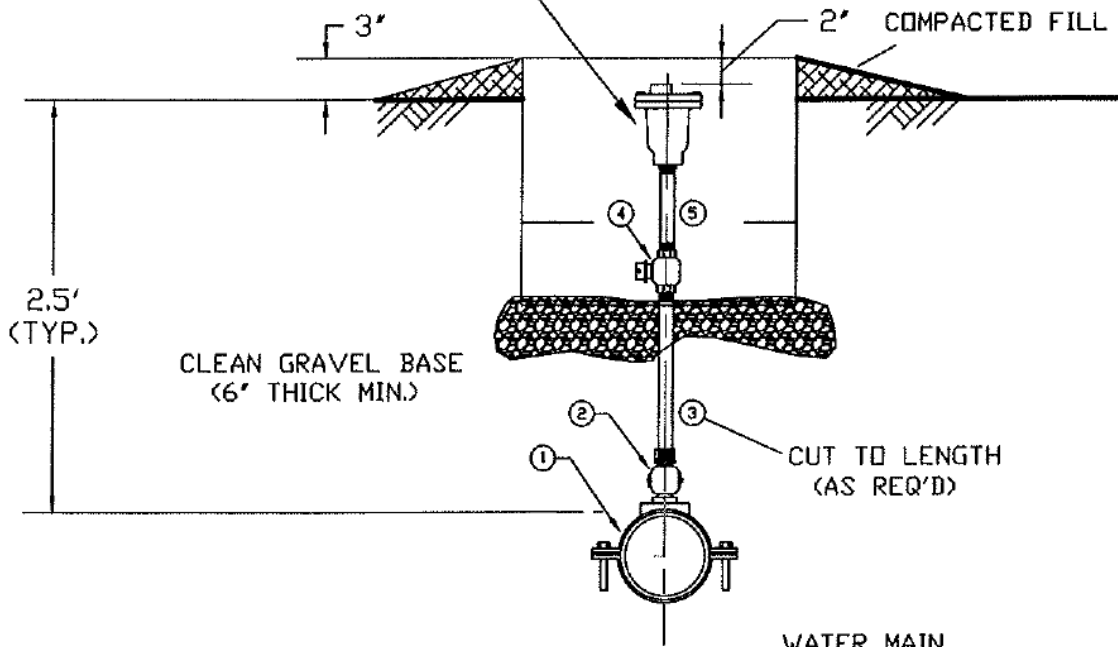

NOTES:

1. FORD SERVICE SADDLE (S71-xx-4)
2. FORD BALLCORP (FB1102-4-NL)
3. BRASS NIPPLE (THREADED BOTH ENDS) 12-INCHES LONG
CUT TO LENGTH AS REQUIRED.
4. FORD BALL VALVE CURB STOP - MODEL B11-444-NL
5. BRASS NIPPLE (THREADED BOTH ENDS) 6-INCHES LONG

WATER MAIN
(PVC SDR-21, 200 PSI)

AIR RELEASE VALVE DETAIL

REV
0

Washington County Rural Water District No. 3

REVISION DATE: FEB. 23, 2015

MAIN LINE
PERPENDICULAR CONNECTION

NOTE:
ALL THREADS TO BE IRON
PIPE THREADS.

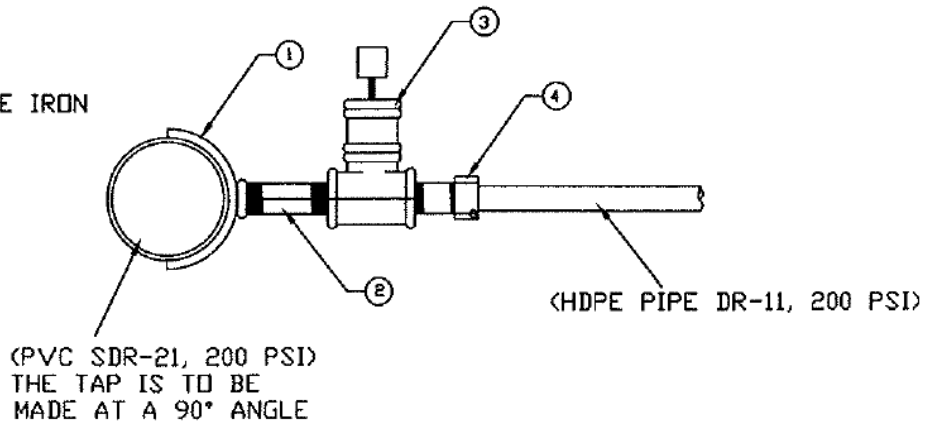

1. FORD BRASS TAPPING SADDLE (S71)
2. BRASS NIPPLE (THREADED BOTH ENDS) 6-INCHES LONG
3. 2-INCH MUELLER GATE VALVE (THREADED) - MODEL A-2360-8
4. FORD PACK JOINT COUPLING - MODEL C87-77

BLIND FLANGE W/ 2-INCH
THREAD TAP.

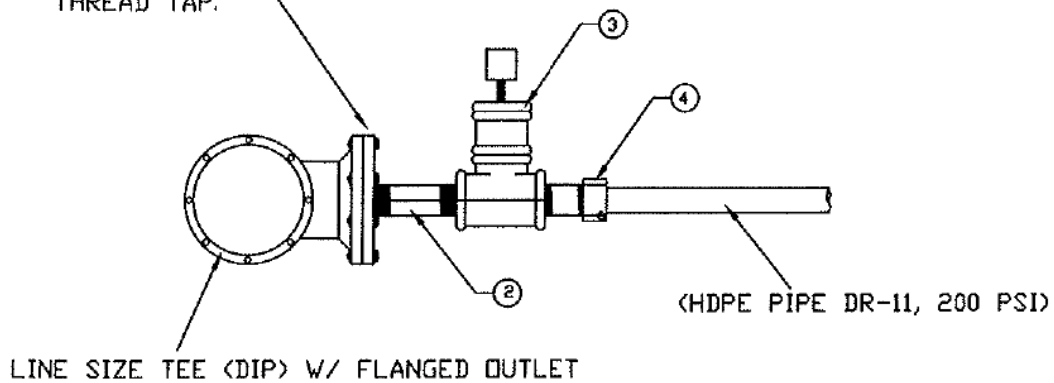

APPROX. SCALE: NONE

2-Inch HDPE Water Line - Transition Details

REV
2

Washington County Rural Water District No. 3

REVISION DATE: JUNE 17, 2019

TYPICAL HDPE TO PVC PIPE TRANSITION

CONCRETE WALL ANCHOR FOR HDPE PIPE (SEE SEPARATE DETAIL)

10' MIN. TO CASING ENTRANCE WHERE CASING IS REQUIRED.

FUSED HDPE WALL RESTRAINT

HDPE PIPE DR-11 (160 PSI)

5' MIN.

HDPE MJ ADAPTER

MJ GLAND

D.I.P. FITTING OR VALVE W/ MJ ENDS

USE DIP FLANGE x MJ ADAPTER WHERE FLANGED FITTINGS OR VALVES ARE REQUIRED

MJ GLAND

MIDCO RESTRAINT PVC PIPE SIDE ONLY (TYPICAL)

WHERE PVC PIPE BELL JOINT RESTRAINTS ARE REQUIRED USE FORD UFR 1350

PVC PIPE SDR-21 (200 PSI)

HDPE TO PVC PIPE TRANSITION DETAIL

REV 0

Washington County Rural Water District No. 3

REVISION DATE: MARCH 21, 2015

TYPICAL HDPE PIPE WALL ANCHOR INSTALLATION

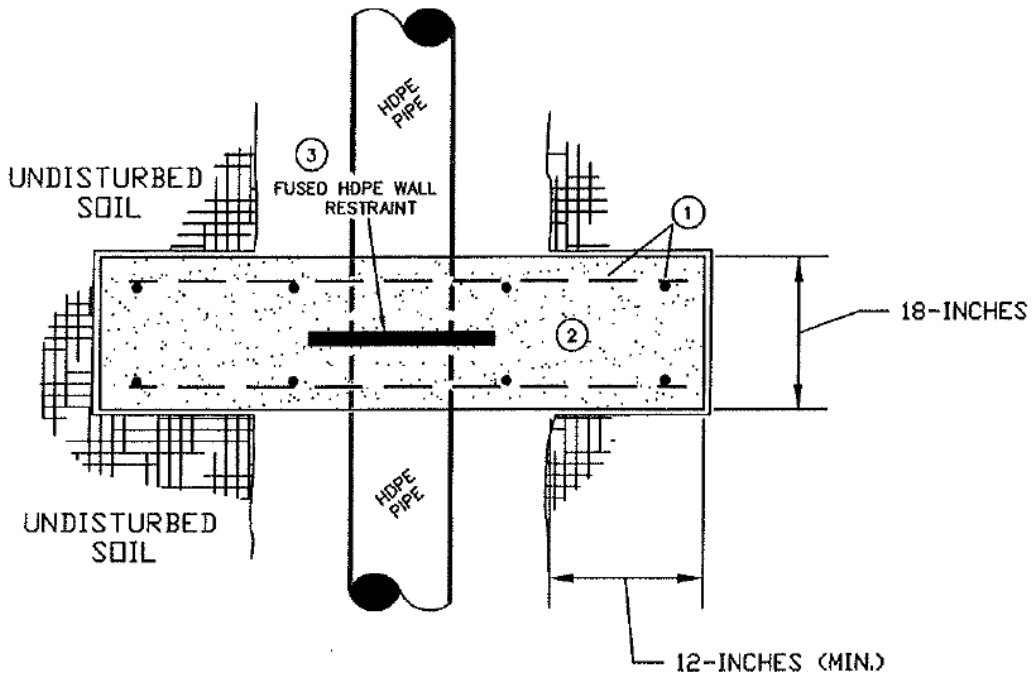

NOTES:

1. #4 REBAR BOTH WAYS - 12-INCH O/C
2. CONCRETE ANCHOR BLOCK (2,500 PSI);
CONCRETE BLOCK TO EXTEND 12-INCHES ABOVE
AND BELOW THE HDPE WALL RESTRAINT;
CONCRETE BLOCK TO BE MINIMUM 10 FEET FROM
PIPE FITTINGS AND CASING ENTRANCES.
3. FUSED HDPE WALL RESTRAINT TO BE ISCO WALL ANCHOR
OR GEORG FISCHER CENTRAL PLASTICS FLEX RESTRAINT.

HDPE PIPE WALL ANCHOR DETAIL

REV
0

Washington County Rural Water District No. 3

REVISION DATE: MARCH 21, 2015

20 FOOT MINIMUM EASEMENT WIDTH

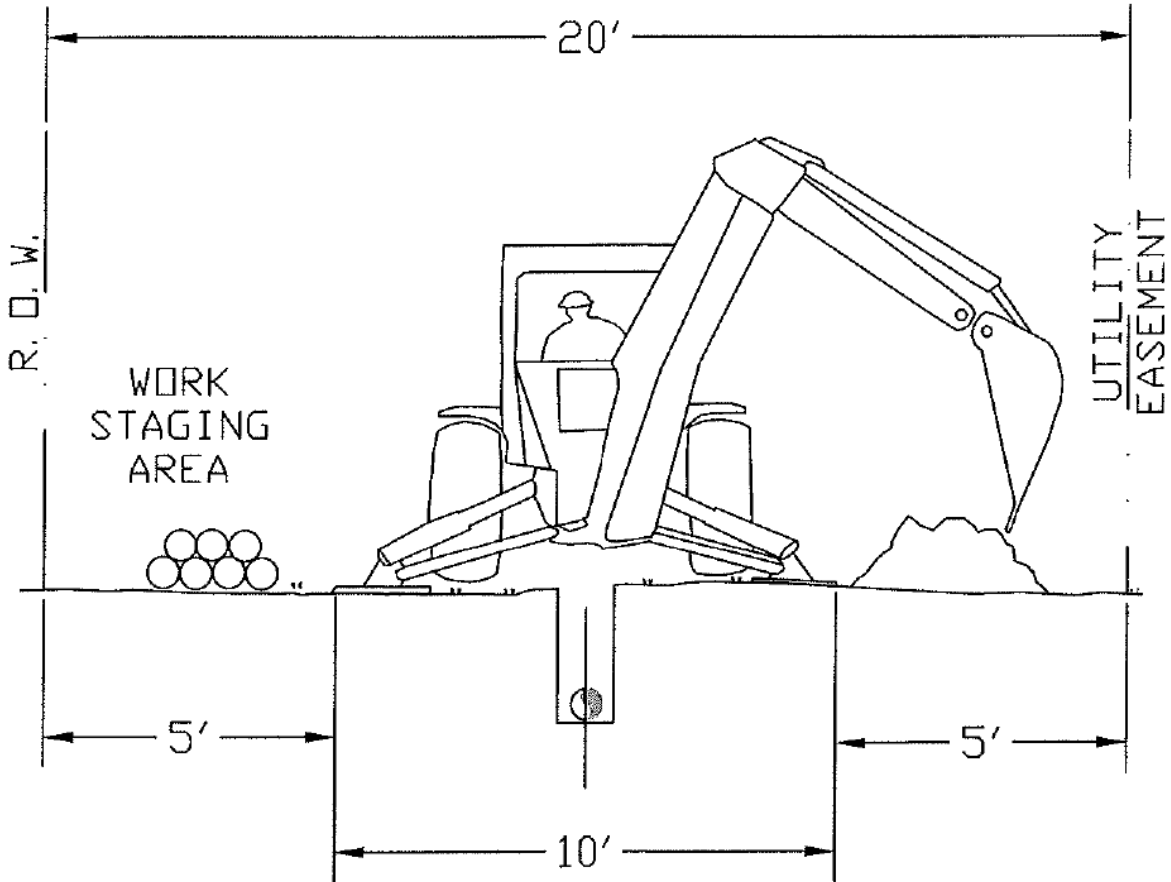

BASED ON CASE 580 SUPER M
LOADER/BACKHOE

Minimum 20' Easement Width

REV
0

Washington County Rural Water District No. 3

REVISION DATE: MAY 1, 2012